

11.3.1 TECHNICAL DATA

MAX OPERATING PRESSURE (PS): 220 bar

PRESSURE TEST (PT): 1.43 x PS

WORKING TEMPERATURE: - 20 ÷ +60°C

MEDIUM: Nitrogen

NITROGEN CONTAMINATION DEGREE:
class 20/18/15 according to ISO 4406/99

MATERIAL BODY AND INTERNAL PARTS: brass

DIAPHRAM: stainless steel

PLATING: chromium plating

SEALS MATERIAL: P = Nitrile RUBBER (NBR) and Delrin

PORT CONNECTIONS: M16x1.5 tube dia. 8

WEIGHT: 1,75 Kg.

11.3.2 DESCRIPTION

The pressure reducer it is used for adjusting the required pre-charge pressure between the nitrogen bottle and the accumulator.

For safety reasons the user it is obliged, when using nitrogen gas bottles, to install a nitrogen reducer.

This nitrogen reducer enables you to reduce the pressure, available from the gas bottle, to the pressure required.

Also with the big hand kinds on the reducer it is easier to adjust the flow of the gas. By using this reducer you eliminate the possibility to over-charge an accumulator which has a lower working pressure than the gas pressure stored on the nitrogen bottle.

The reducer is easy to adjust to the required gas pressure.

Also the connections fit directly to the gas bottle (using the nipple 11447) and the charging hose of the EPE pre-loading set.

The reducer has a heavy duty construction and it is suitable for nitrogen gas bottles, 200 bar max.

Standard version includes:

- 2 pressure gauges, indicating pressure of gas bottle and reduced pressure out. Pressure range is 0-300 bar.
- Reduction pressure is adjustable from 0 to 200 bar.

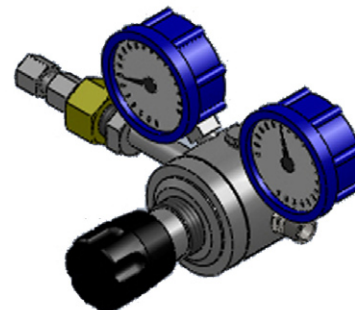

11.3a

11.3.3 HYDRAULIC SYMBOL

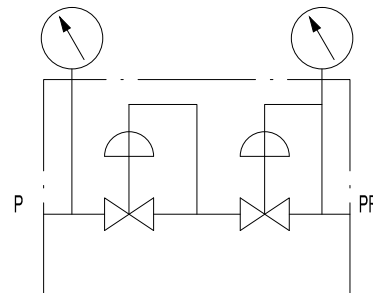

11.3b

11.3.4 MOUNTING

During the setting up operations, all components in contact with gas must be free of grease and oil.

Follow scrupulously the instructions either before then during the operations. Before installation check that the pressure regulator is suitable to work with the specific gas.

Check that the connections are clean and not damaged, otherwise the reducer has not to be installed. Before connection of the regulator, open and close completely the valve of the bottle to remove any possible impurity.

Never stay and put your hand in front of the bottle valve.

Tighten the nut or the hanger (1 - 7) to connect the pressure of the bottle valve.

The regulator has to be placed as showed in drawing 11.3C and the adjusting screw have to be unloosen turning it anticlockwise.

Connect the regulator to the system by the outlet fitting. Open slowly the valve of the bottle and the inlet gauge will show the bottle pressure.

Adjust the outlet pressure on the gauge turning clockwise the adjusting screw.

11.3.5 ORDER CODE

B2494	/	8
-------	---	---

Scale of pressure gauge (bar)	
Outlet pressure:	
1 ÷ 8 bar	8
1,5 ÷ 15 bar	15
3 ÷ 30 bar	30
5 ÷ 50 bar	50
10 ÷ 100 bar	100
30 ÷ 200 bar	200

Special variants on request

11.3.6 DIMENSIONS

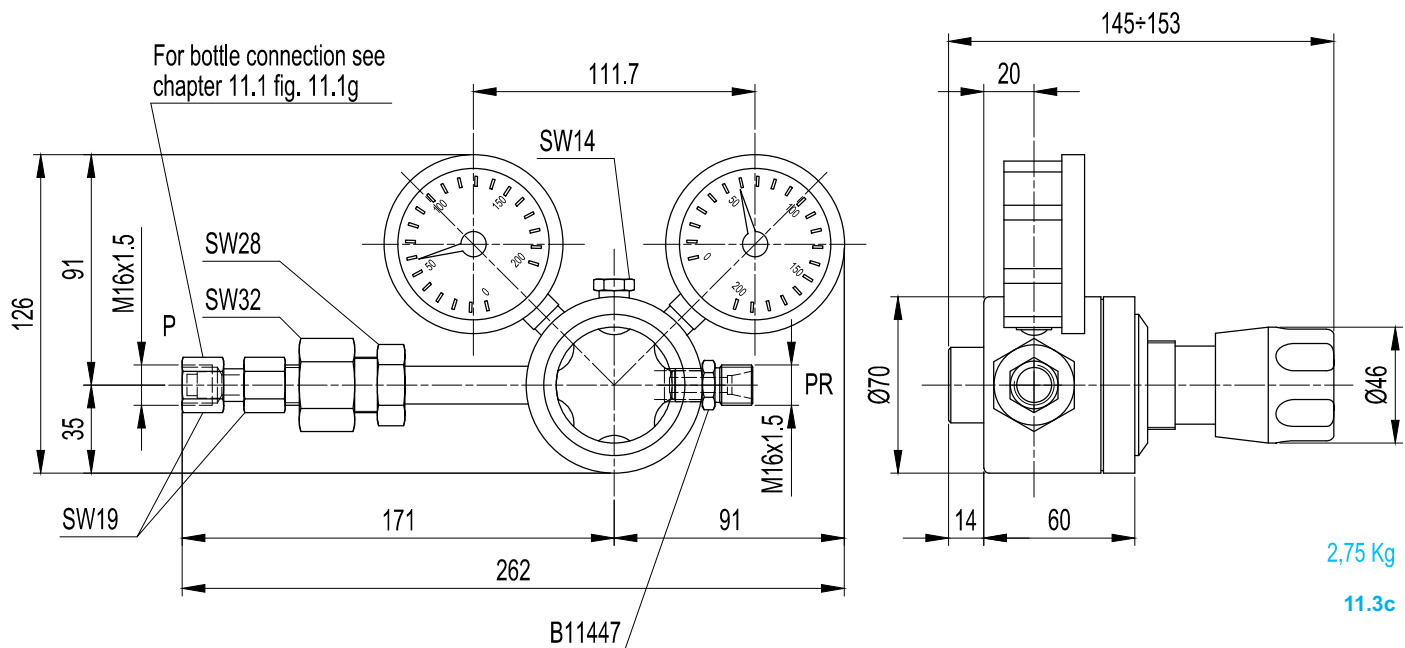

Model	Inlet max pressure bar	Outlet pressure bar	Max flow Nm ³ /h	Regulation system	Gauges IN bar	Gauges OUT bar
B2494/8	220	1 ÷ 8	30	Diaphragm	0 ÷ 315	0 ÷ 16
B2494/15	220	1,5 ÷ 15	45	Diaphragm	0 ÷ 315	0 ÷ 25
B2494/30	220	3 ÷ 30	60	Piston	0 ÷ 315	0 ÷ 63
B2494/50	220	5 ÷ 50	60	Piston	0 ÷ 315	0 ÷ 100
B2494/100	220	10 ÷ 100	60	Piston	0 ÷ 315	0 ÷ 160
B2494/200	220	20 ÷ 200	60	Piston	0 ÷ 315	0 ÷ 315

11.3d

11.3.7 INSTRUCTIONS

Avoid that the reducer could be damaged (by duly visual check). Don't change calibration of the over-pressure valve. Keep gasket and gauges in perfect conditions.

In case of bad working of the pressure reducer (e.g. raising of outlet pressure without consumption, gauges and safety valve's leakage) lock immediately the flow to the reducer closing of the bottle valve.

11.3.8 REPAIRING

The pressure reducer must be repaired only by skilled personnel or in our factory. Original spare parts are compulsory for EPE ITALIANA guarantee.

EPE ITALIANA will not respond for arbitrary repair or changing made by users or other persons without its previous autorisation.

Reproduction is forbidden.

In the spirit of continuous improvement, our products may be changed.