

## 3.6.1 TECHNICAL DATA

**MAX OPERATING PRESSURE (PS):** 16 bar

**PRESSURE TEST (PT):** 1.43 x PS

**NOMINAL CAPACITIES:** 100 - 150 - 200 - 300 - 500 - 750 - 1000 - 1500  
- 2000 - 3000 - 4000 - 5000 litres

**WORKING TEMPERATURE:** -30 ÷ +100 °C

**COMPRESSION RATIO (P<sub>0</sub> : P<sub>2</sub>):** max. 1 : 4

**FLUID VISCOSITY RANGE:** 10 ÷ 400 cSt

**RECOMMENDED VISCOSITY:** 36 cSt

**FLUID CONTAMINATION DEGREE:**  
class 21/19/16 according to ISO 4406/99

**BODY MATERIAL:**

- carbon steel shell painted with rust inhibitor RAL 5015 up to 1500 lt;
- RAL 9010 for capacities from 2000 lt to 5000 lt
- stainless steel AISI 316L

**VALVES MATERIAL:**

- phosphated or galvanized carbon steel in compliance with Directive 2002/95/EC (RoHS) to resist to corrosion
- stainless steel AISI 316L

**BLADDER MATERIAL:**

- **P** = Nitrile rubber (NBR)
- **B** = Butyl (IIR)
- **E** = Ethylene-propylene (EPDM)

See Table 3.6c and/or Chapter 1.5

**FILLING VALVE CONNECTION:**

- 5/8"-UNF std
- 7/8" UNF
- 1/4" BSP

**FLUID PORT CONNECTION:** see Table 3.6e

**FLOW RATE:** see Table 3.6e

**WEIGHT:** see Table 3.6e

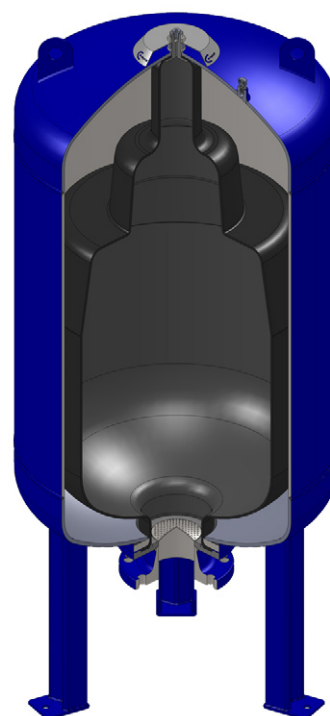

3.6a

## 3.6.2 HYDRAULIC SYMBOL

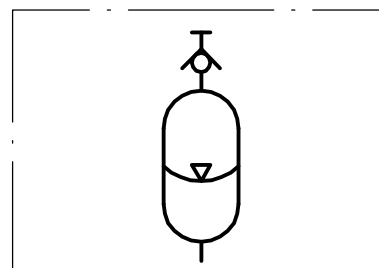

3.6b



### 3.6.3 “ASE” BLADDER ADVANTAGES

- dirt tolerant
- light weight
- compact
- simple construction
- quick response
- works well on water, low lubricity fluids
- quick, easy installation
- low cost

### 3.6.4 DESCRIPTION

ASE Bladder-type accumulators consist of a cylindrical pressure vessel made of high-tensile steel.

The accumulator is subdivided into a gas and fluid side by an elastic bladder mounted in the interior of the vessel.

The nitrogen is charged to the specified gas charge pressure  $P_0$  by means of gas valve at the external of the bladder.

When the fluid is pressed into the bladder, the gas in the accumulator is compressed and hence the pressure increased. The gas volume reduces and on the fluid side, the fluid can flow into the bladder. As soon as the pressure on the fluid side falls below the gas pressure, the accumulator is emptied.

A special oil valve (anti-extrusion plate) is provided in the oil port in order to prevent draining of the bladder into the oil channel and thus the bladder from being destroyed.

When the minimum operating pressure is reached, a small oil volume is to be maintained between the bladder and the fluid volume (approx. 10% of the nominal capacity of the hydraulic accumulator), in order that the bladder does not hit the valve during every expansion process.

Gas valve consists of a sealing cap, a filling valve and an adapter.

The nameplate shows the technical data and features of the hydraulic accumulator.

### 3.6.5 EUROPE MARKET

All hydraulic accumulators are pressure vessels and are subject to the national regulations and directives, valid at the place of installation.

Every shipping batch is complete of a conformity declaration and instruction of use and maintenance and/or all documents requested.

All vessel categories (see Table 3.6e) must be protected by means of a pressure relief valve in accordance with Directive 2014/68/EU.

### 3.6.6 ACCESSORIES

For gas side's safety equipment, see Cap. 8

For fluid side's safety equipment, see Cap. 9

For pre-loading and charging set, see Cap. 11

For other components, see Cap. 12

### 3.6.7 BLADDER-TEMPERATURE-LIQUID COMPATIBILITY

When selecting the accumulator variant, pay attention to the following non-binding notes with regard to hydraulic fluid, bladder material and the permissive temperature range. (see Section 1.5)

Code letter	Polymer	ISO	Temperature range (°C)	Some of the liquids compatible with the polymer
P	Standard nitrile (Perburan)	NBR	-20 ÷ +80	Aliphatic hydrocarbons (propane, butane, gasoline, oils, mineral greases, diesel fuel, fuel oil, kerosene), mineral greases and oils, HFA - HFB - HFC fluids, many dilute acids, alkalis, saline solutions, water, water glycol.
E	Ethylene-Propylene	EPDM	-30 ÷ +100	Hot water up to 100°C, glycol-based brake fluids, many organic and inorganic acids, detergents, solutions of sodium and potassium, phosphate ester-based hydraulic fluids, (HFD-R), silicone oils and greases, many polar solvents (alcohol, ketones, esters), Skydrol LD4 and 500B-4, resistance to ozone, aging and weathering.

For other hydraulic fluid and/or temperatures, please consult us.

3.6c

## 3.6.8 ORDER CODE

1	2	3	4	5	6	7	8	9	10	11	12	13	14	15			
ASE	500	P	16	C	B	4/150	V	-	0	-	C	0	C	0	ELM25	/	1,5

<b>1 Series</b>
Bladder accumulator = ASE

<b>2 Nominal capacity</b>
100 lt = 100
150 lt = 150
200 lt = 200
300 lt = 300
500 lt = 500
750 lt = 750
1000 lt = 1000
1500 lt = 1500
2000 lt = 2000
3000 lt = 3000
4000 lt = 4000
5000 lt = 5000

<b>3 Bladder material</b>
Nitrile rubber (NBR) = P
Ethylene-propylene (EPDM) = E

<b>4 Max working pressure (PS)</b>
See the table on front page

<b>5 Body material</b>
Carbon steel = C
Stainless steel = X

<b>6 Fluid port connection</b>
Flange ANSI = B
Flange UNI = U

<b>7 Dimension of the connection fluid</b>
For the type of connection:
B = DIMENSION/RATING
Former. 4" ANSI 150 = 4/150
U = DN/PN
Former. DN100 PN10 = 100/10
Special variants upon request

<b>15 Precharge pressure (bar)</b>
Standard 1.5 bar = 0 ÷ 6 (< PS)

<b>14 Other variants</b>
See the table on front page

<b>13 Variants of gas side</b>
Standard = 0
Other numbers/variants to be requested EPE

<b>12 Gas valve material</b>
Carbon steel = C
Stainless steel = X

<b>11 Variants of fluid side</b>
Standard = 0
Other numbers/variants to be requested EPE

<b>10 Fluid valve material</b>
Carbon steel = C
Stainless steel = X

<b>9 Testing and certification</b>
Factory testing = 0

<b>8 Type of filling valve</b>
Standard filling valve 5/8" UNF thread = V
Standard filling valve with 5/8" UNF thread in stainless steel = VX
Without filling valve (thread hole M12x1.5) = V0
Brass filling valve 1/4" BSP = V2
Filling valve 7/8" UNF = V4

Special variants upon request

4 Max working pressure (PS)		
Capacity litres	Carbon steel	Stainless steel
100 ÷ 500	<b>10 - 16</b>	<b>10 - 16</b>
750 ÷ 5000	<b>10</b>	<b>10</b>

14 Other variants
Dumper + Safety valve, type VS2470-11 set at 11 bar = <b>F11</b>
Dumper + Needle Valve of 1/4" BSP = <b>EG2</b>
Dumper + Stainless steel needle Valve of 1/4" BSP = <b>EG2X</b>
Dumper + excluding device with with full scale pressure gauge of xxx bar (see Section...) = <b>EMxxx</b>
Dumper + excluding device of 90° with full scale pressure gauge of xxx bar = <b>ELMxxx</b>
Flushing with degree of contamination ≤ ...class = <b>Fx</b>
75-80 μ thick polyurethane paint with colour to be specified = <b>Wxxx</b>
Off-shore paint with colour to be specified = <b>Zxxx</b>
NORSOK System 1 paint with colour to be specified = <b>K1</b>
NORSOK System 7B paint with colour to be specified = <b>K7B</b>
other variants upon request

## 3.6.9 DIMENSIONS

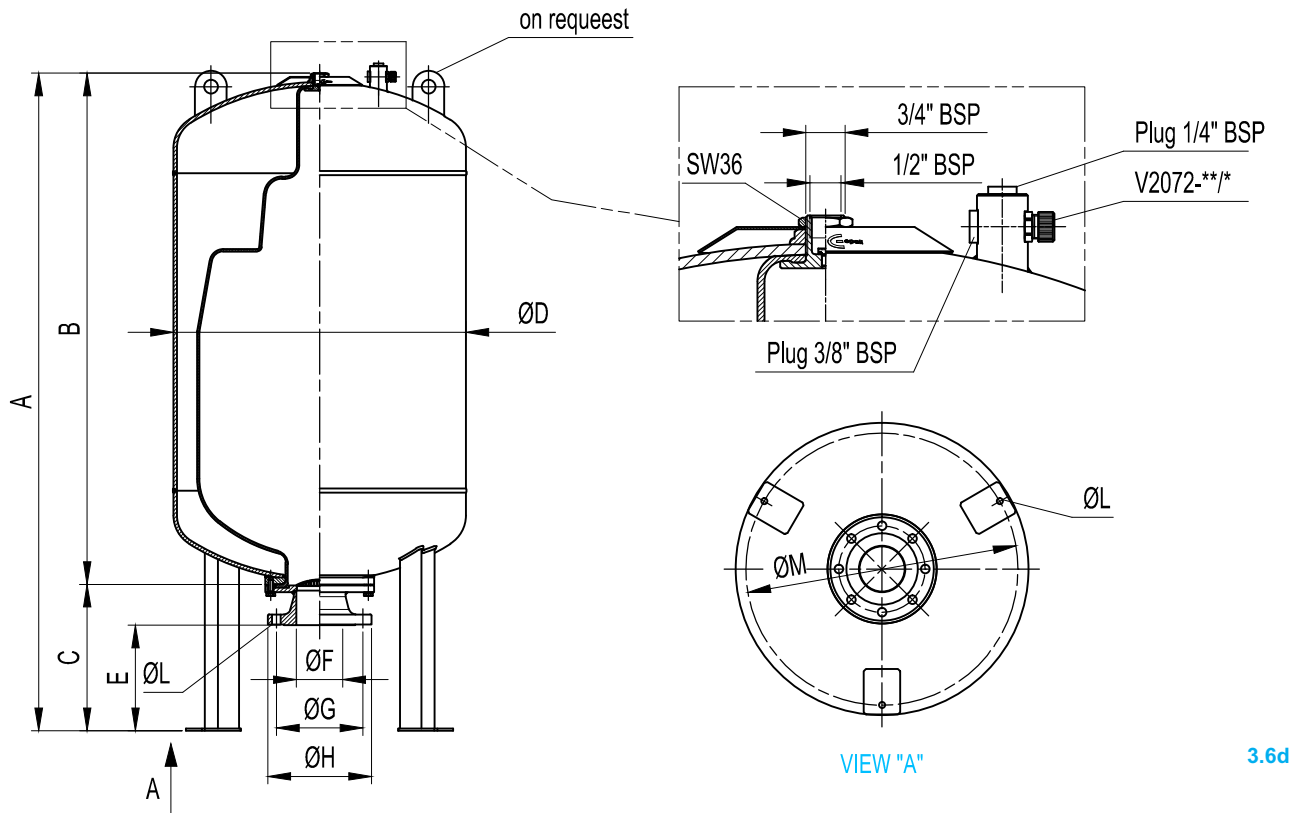

3.6d

Acc. type ASE in carbon steel and stainless steel	Nominal gas volume liters	Working pressure bar	Ped category liquids of group 2	Max.diff. pressure P2-P1 bar	Flow rate l/min	Max.comp. ratio P0/P2	A ± 50 mm	B±30 mm	C mm	Ø D ± 10 mm	E ± 50 mm	ØF mm	ØG mm	ØH mm	ØL mm	N° fixing holes	ØM mm	Acc. dry weight kg
ASE 100	100	10 ÷ 16	II ÷ III	4	300	1:4	880	720	160	460	85	102,4	190,5	233	19	8	390	18
ASE 150	150	10 ÷ 16	III	4	300	1:4	1030	870	160	510	85	102,4	190,5	233	19	8	440	22
ASE 200	200	10 ÷ 16	III ÷ IV	4	300	1:4	1070	885	185	590	110	102,4	190,5	233	19	8	440	35
ASE 300	300	10 ÷ 16	III ÷ IV	4	300	1:4	1250	1085	165	650	90	102,4	190,5	233	19	8	440	45
ASE 500	500	10 ÷ 16	III ÷ IV	4	300	1:4	1600	1360	240	750	165	102,4	190,5	233	19	8	550	60
ASE 750	750	10	IV	4	300	1:4	1820	1520	300	800	225	102,4	190,5	233	19	8	648	75
ASE 1000	1000	10	IV	4	300	1:4	2130	1820	310	800	235	102,4	190,5	233	19	8	-	85
ASE 1500	1500	10	IV	4	300	1:4	2130	1850	280	1000	205	102,4	190,5	233	19	8	790	105
ASE 2000	2000	10	IV	4	300	1:4	2550	2140	410	1100	335	102,4	190,5	233	19	8	930	140
ASE 3000	3000	10	IV	4	300	1:4	2930	2580	350	1250	275	102,4	190,5	233	19	8	1090	205
ASE 4000	4000	10	IV	4	300	1:4	3030	2600	430	1450	355	102,4	190,5	233	19	8	1250	250
ASE 5000	5000	10	IV	4	300	1:4	3800	3410	390	1450	315	102,4	190,5	233	19	8	1155	310

3.6e

- The maximum differential pressure is the maximum allowable difference between the maximum pressure and the minimum working pressure (P2-P1) to have an infinite life cycle of the accumulator (greater than 2,000,000 cycles).

- Flow rate measured using mineral oil with viscosity of 36 cSt at 50°C and  $\Delta P = 5$  bar

## 3.6.10 SPARE PARTS CODE

Item	Description	Q.ty	Type					
			ASE 100	ASE 150	ASE 200	ASE 300	ASE 500	ASE 750
1	Bladder	1	S100*** - 0	S150*** - 0	S200*** - 0	S300*** - 0	S500*** - 0	S750*** - 0
2	Gas-fill valve	1	V 2072 - ** / *					
Item	Description	Q.ty	Type					
			ASE 1000	ASE 1500	ASE 2000	ASE 3000	ASE 4000	ASE 5000
1	Bladder	1	S1000*** - 0	S1500*** - 0	S2000*** - 0	S3000*** - 0	S4000*** - 0	S5000*** - 0
2	Gas-fill valve	1	V 2072 - ** / *					

\* Gasket material    \*\* Component material    \*\*\* Bladder material

3.6f

## 03.6.11 COMMISSIONING AND MAINTENANCE

### Delivery conditions

Bladder accumulators are delivered pre-charged with nitrogen at a pressure of 1.5 bar or at value of pressure required at time of order. The pre-charge value is also on the nameplate of the accumulator. The bladder accumulators type ASE are shipped in cartons on pallets or, upon request, in wooden crates. Unless otherwise required, certificates and documentation are provided together with the accumulators.

### Handling

The original packaging is suitable for handling and general storage. Where necessary, you should use suitable lifting equipment to support the weight of the accumulators.

However protect from impact the packaging and handle it with care.

### Storage

During storage in the warehouse, leave the product in its original packaging, keeping it away from heat sources and naked flames. The storage temperature should be between +10 and +40°C.

After six years of storage, it is essential to proceed with the replacement of all elastomeric parts before the commissioning.

### Marking on the nameplate of the accumulator

With reference to the PED 2014/68/EU classification, Article 3, Paragraph 3 and / or risk categories I or II depending on the volume and maximum working pressure, the accumulator indicates the following data:

- Logo, name and country of the manufacturer
- Month/year of production
- Product code
- Serial number
- Maximum PS pressure and PT test pressure in bar
- Min. and max. TS working temperature in Celsius
- Volume V in litres
- Group of fluids allowed
- CE marking (for volumes exceeding 1 litre) with the identification number of the notified body
- Pre-charge pressure in bar

### It is strictly forbidden to:

- weld, rivet or screw any item of the accumulator
- engrave or permanently stamp the surfaces of the accumulator shell and / or carry out other operations that could affect or change the mechanical properties of the accumulator
- use the accumulator as a structural element: it should not be subjected to stresses or loads
- change the data of the nameplate and / or accumulator without the permission of the manufacturer

- use a (dangerous) fluid of Group 1 with equipment designed and manufactured for fluids of Group 2.

### Installation

Before installation, you must perform a visual check to verify that the accumulator has not suffered any damage during shipping / handling.

Verify that the requested type matches with what stamped on the nameplate. We recommend using the accumulator with a suitable security valve (see Chapter 8) or a security block type BS (see Chapter 9).

This device provides user and equipment protection against possible damage caused by pressure surges and also makes the maintenance of the accumulator easier, facilitating the interception and the discharge. Provide for a space of 200 mm above the gas pre-charge valve to allow access to and control of the pre-charge equipment (see Chap.11.1).

The accumulators type ASE may be installed with the pre-charge valve at the top, and the nameplate must be visible. Proceed to the assembly so that no abnormal force affects the pipes connected directly or indirectly to the accumulator. Make sure the fluid is compatible with the elastomer of the bladder. Check that the max. allowed accumulator pressure is equal to or greater than that of the hydraulic circuit and that the temperature during operation is maintained within the range expected.

Make sure the fluid does not contain contaminants and/or abrasive.

### Pre-charge of nitrogen

Normally, the bladder accumulators are delivered pre-charged with pressurized gas. The pre-charge of gas can be controlled and / or adjusted before or after installation of the accumulator in the hydraulic circuit.

For the pre-charge, use only industrial dry nitrogen with a purity of min. 99%. It is important to use the nitrogen from a bottle equipped with a pressure reducing valve (see Chap.11.3). Use the EPE pre-charge and charging set type PC to check the charging pressure required, and adjust if necessary. If the pre-charge pressure is lower than required, connect the charging hose on one side and the other side connect it to the nitrogen bottle or to the pressure reducer. Slowly fill the nitrogen in the accumulator until reaching a pressure slightly higher than that set value (+ 10 ÷ 15%). Close the bottle and remove the charging hose from the pre-loading set; wait until the gas temperature has stabilized (2 hours) and calibrate the pressure, discharging the excess gas. Make sure that the gas valve is not subject to losses and, if necessary, use soap and water.

Tighten the protective caps manually.

### Hydraulic pressurization

- Check that the pre-charge pressure is adequate for the application
- Ensure that the hydraulic pressure never exceeds the max pressure allowed (PS) shown on the accumulator shell.

To avoid this risk, use a safety device (see Chap. 9).

### Maintenance

- Periodically check the pre-charge pressure of the gas: after the commissioning, check after 2-3 weeks of operation and if there were no leaks, repeat the operation after 3 months; if the pressure at the same temperature was stable, repeat the test yearly.  
For heavy-duty applications, check the pre-charge every 6 months.
- Periodically (yearly) carry out a visual inspection of the accumulator in order to detect any early signs of deterioration such as corrosion, deformation, etc.
- Comply with the requirements of the regulations concerning the verification of the functionality of the equipment according to the country of installation of the accumulator.

### Repair

If for failure, scheduled check or retest it is necessary to remove the accumulator from the system, prior to removal, isolate the accumulator from the installation and discharge pressure of the liquid. It may consist in replacing the bladder, the seals, the pre-charge valve and/or the parts of the gas and fluid valve. For reasons of functionality and security, it is recommended to use only original spare parts.

### Demolition and recycling of the accumulator

Before accumulator demolition or recycling, you should always discharge completely the pre-charge pressure and remove the gas valve. If needed, proceed decontaminating in relation to the fluid used prior to demolition.

## 3.6.12 REPAIR TOOLS

### 3.6.12.1 BLADDER PULL ROD

The pull rod screwed for the gas valve of the bladder for easy assembly into shell during rassembley. Pull rod is complete with fitting for EPE gas valve and 3 extension segments to accomodate all size of accumulators. Code for complete kit: **B2505-P4**.

#### Dimension

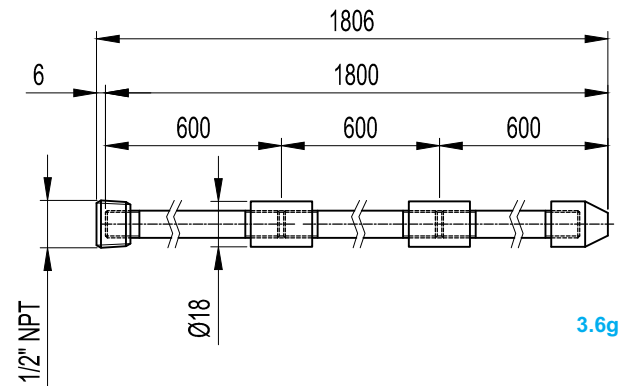

### 3.6.12.2 CORE TOOL

The core tool is used to remove and reinstall the valve core type V4. Code **B2508**

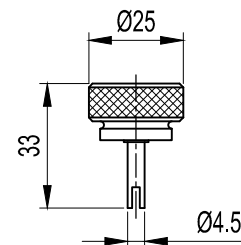

Reproduction is forbidden.

In the spirit of continuous improvement, our products may be changed.