

8.1.1 TECHNICAL DATA

MAX OPERATING PRESSURE (PS): 400 bar

PRESSURE SETTING (P): 10 ÷ 400 (upon request)

ORIFICE: 8 mm

LIFT: 3.3 mm

WORKING TEMPERATURE: -40 ÷ +150 °C

REPETIBILITY: ± 3% of P

CALIBRATION ERROR: < 3%

OVERPRESSURE BY FULL FLOW: 10% of P

BLOW DOWN: 15% of P

GAS DISCHARGE COEFFICIENT (K): 0.95

BODY MATERIAL: stainless steel AISI 316L

SEALING MATERIAL: Duplex Stellite®

CONNECTIONS: 3/4" BSP ISO228

FLOW RATE: see Table 8.1.11

WEIGHT: 2,16 Kg.

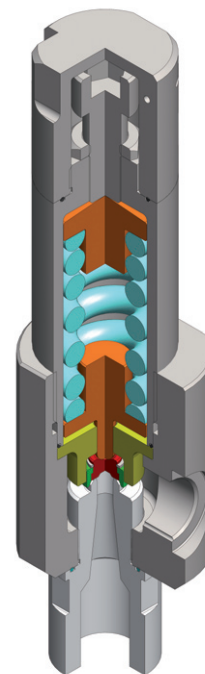

8.1a

8.1.3 HYDRAULIC SYMBOL

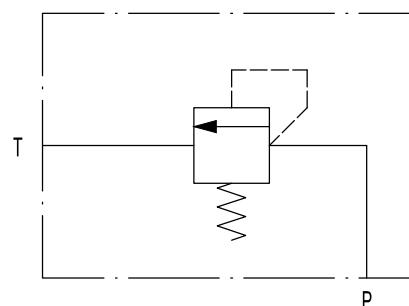

8.1e

8.1.2 DESCRIPTION

The safety valves VS224 are designed and manufactured by Epe Italiana. They have soft seal and total lift. They have a high flow coefficient (K = 0.95) and are suitable for gas and liquids.

VS224 valves are safety devices as specified in Article 1, Section 2.1.3 of Directive 2014/68/EU and are subject to Article 3, Section 1.4 of the same Directive.

These valves are direct acting safety valves, used for protection against overpressure with respect to the operating conditions of the accumulators. They can be installed directly on the accumulator, through the appropriate use of adapters (see Cap.8.3) or on the safety block gas side (BC32G) or on manifold on the gas side of the accumulator stations.

The valve opening is determined by the force exerted by the fluid under pressure on the poppet in contrast with the spring acting on the cut-off itself.

8.1.4 CONSTRUCTION

Body: of stainless steel AISI316L, obtained by mechanical processing, in which are obtained the connections and the seal seat.

Poppet: obtained by mechanical processing from bar and provided with a seal, it ensures the necessary seal degree on the valve seat. The seal is made of Duplex Stellite®, a material that, over the estimated useful life for the valve, maintains good strength and does not cause phenomena of poppet sticking on the seat. The poppet is well led and pushed by the spring.

Spring: it counteracts the pressure and the dynamic actions of the fluid and always ensures the closing of the valve after the discharge. The coils of the spring, even when the poppet has reached its maximum lift, are never at pack.

The poppet has a mechanical lock and when it has reached it, the arrow of the spring does not exceed 85% of the maximum deviation.

Calibration system: threaded hexagon head screw which screws into the top of the valve by compressing the spring below. After the calibration, the position of the adjusting screw is kept unaltered by locking the counter nut and sealing the adjusting screw to the body.

8.1.5 CALIBRATION

All valves are calibrated on the test bench with atmospheric counter pressure. The repeatability error of calibration is less than 3% of P.

The leak test is performed according to API Standard 527: with air and up to a pressure equal to 97% of the calibration pressure verifying that there's no leakages.

8.1.6 ORDER CODE

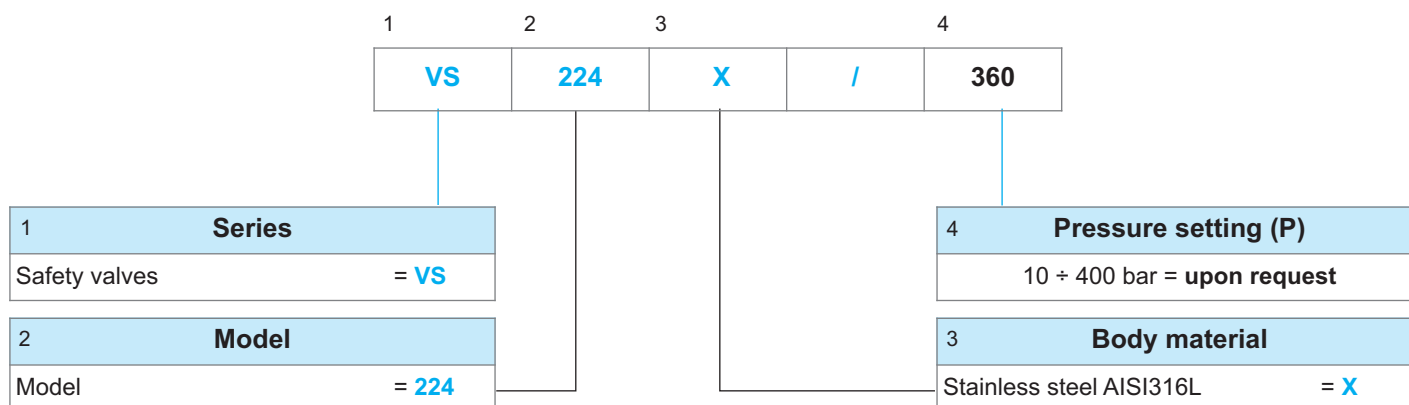

8.1.7 DIMENSIONS

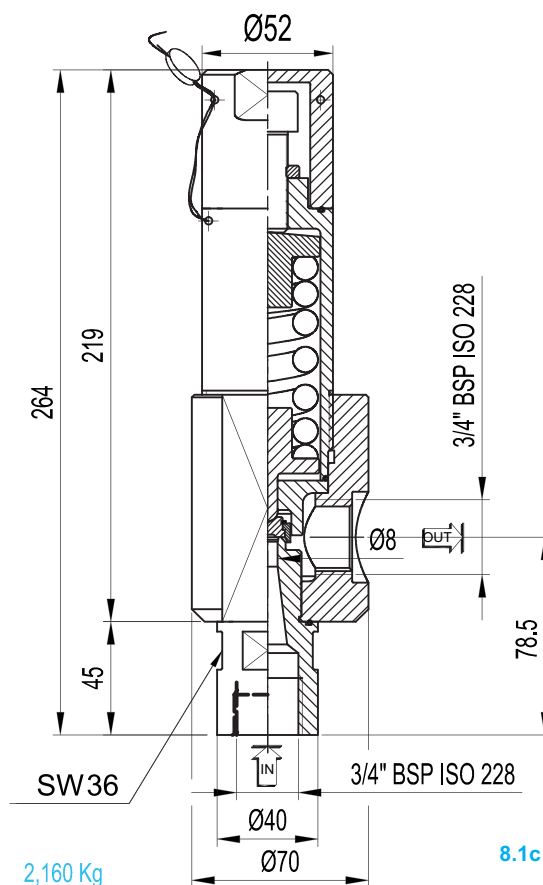

8.1.8 TECHNICAL DATA

MAX OPERATING PRESSURE (PS): 413 bar

PRESSURE SETTING (P): 10 ÷ 413 (upon request)

ORIFICE: 9,5 mm

LIFT: 2.1 mm

WORKING TEMPERATURE: -20 ÷ +150 °C

REPETIBILITY: ± 3% of P

CALIBRATION ERROR: < 3%

OVERPRESSURE BY FULL FLOW: 10% of P

BLOW DOWN: 7% of P

GAS DISCHARGE COEFFICIENT (K): 0.95

BODY MATERIAL: carbon steel A105

SEALING MATERIAL: AISI 431

CONNECTIONS: 3/4" BSP (IN), 1" BSP (OUT)

FLOW RATE: see Cap. 8.1.18

WEIGHT: 2,65 Kg.



8.1.10 HYDRAULIC SYMBOL

8.1d

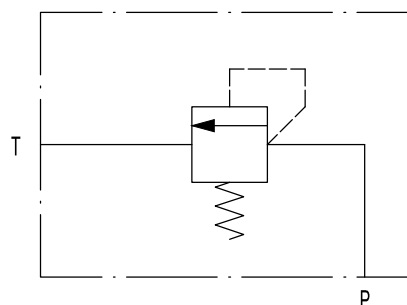

8.1e

8.1.9 DESCRIPTION

The safety valve VS214 is a full nozzle, full lift type valve. It has a high discharge coefficient ($K=0.95$) and is suitable both for gas and fluids. VS214 valves are safety devices as specified in Article 1, Section 2.1.3 of Directive 2014/68/EU and are subjected to Article 3, Section 1.4 of the same Directive.

Those valves are direct acting safety valves, used for protection against overpressure with respect to the operating conditions of the accumulators. They can be installed directly on the accumulator, using the proper adapters (see Cap. 8.3), or on the safety block gas side (BC32V see Cap. 8.6) or can be installed on gas manifolds of accumulator stations.

8.1.11 CONSTRUCTION

Body and bonnet: made from castings.

Seal: the valve has a flat, metal to metal seat

Spring: it counteracts the pressure and the dynamic actions of the fluid and always ensures the closing of the valve after the discharge.

Calibration system: threaded hexagon head screw which screws into the top of the valve by compressing the spring below. After the calibration, the position of the adjusting screw is kept unaltered by locking the counter nut and sealing the adjusting screw to the body.

8.1.12 CALIBRATION

All valves are calibrated on the test bench with atmospheric counter pressure. The repeatability calibration error is less than 3% of P.

The leak test is performed according to API Standard 527 with air and up to a pressure equal to 97% of the calibration pressure verifying that there's no leakages.

8.1.13 ORDER CODE

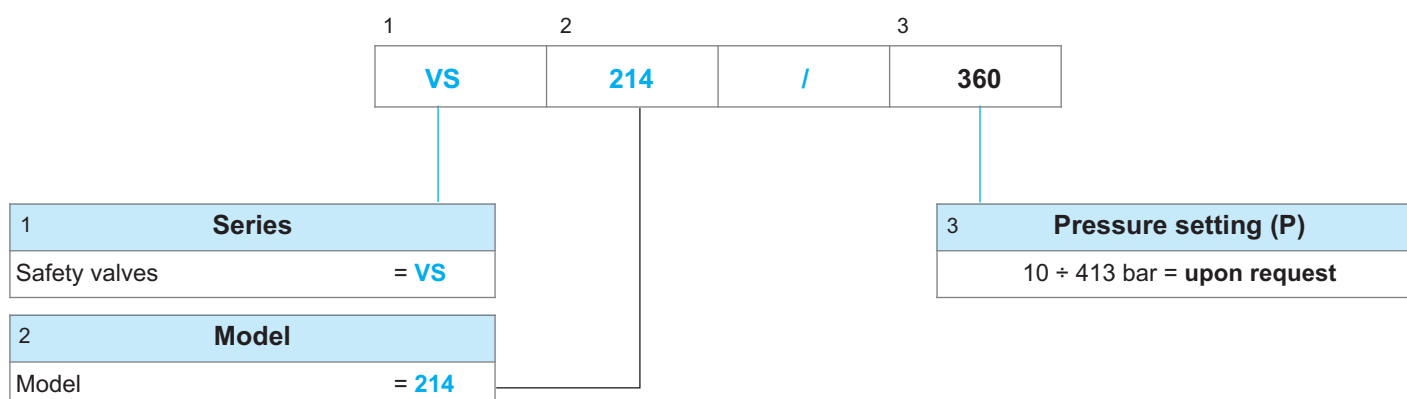

8.1.14 DIMENSIONS

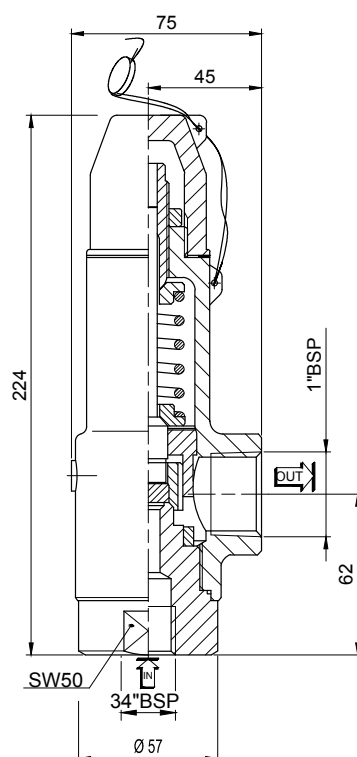

8.1f

8.1.15 EUROPEAN MARKET

Directive 2014/68/EU provides that pressure equipment, in which it's reasonably expected to be exceeded the allowable limits, should be provided with adequate protective equipment; for example, safety accessories such as safety valves type VS or burst disk type DR (see Chap. 8.2). These devices shall prevent that pressure permanently exceeds the maximum allowable pressure PS of the equipment protected by them.

However, it is permissible a pressure peak of short duration limited to 10% of the maximum allowable pressure.

For the choice and sizing of the adequate safety device, the user should refer to specific standards.

In accordance with the regulations 2014/68/EU, the safety valves are classified in Category IV.

8.1.16 ACCESSORIES

Two-way shut-off valves, see Chap. 8.4

Three-way shut-off valves, see Chap. 8.5

Gas side dumpers, see Chap. 8.3

8.1.17 COMMISSIONING AND MAINTENANCE

Installing the valves

Regarding the installation of the safety valves, you should be kept in mind the following key points:

- the safety valves must be installed in the area that need to be protected from overpressure in the vertical position with the inlet connection facing down;
- the vessels, connected each other by appropriate piping with a diameter adapted by the Manufacturer and User and on which there weren't interposed interceptions, can be considered for the installation of the safety valves, as a single vessel;
- the connection between the valve and the equipment to be protected should be as short as possible and must not have a cross section smaller than the one of the valve inlet. In any case, the standard EN 13136:2001/A1: 2005 states that the pressure drop between the protected vessel and the safety valve, at flow rate of full discharge, should not exceed 3% of the pressure value P, including any accessory inserted on the line;
- the choice of the safety valve displacement should consider that the operation of the valve results in the discharge of the gas under pressure, if not sent directly to atmosphere.

Where there is a risk of causing direct damage to individuals who are nearby, you will have to provide a pipe for conveying the discharge, sized so as not to affect the operation of the valve.

Standard EN 13136:2001/A1: 2005 requires that this pipeline should not generate, at full capacity, a pressure higher than 10% of the value of the calibration pressure for conventional unbalanced valves.

Disassembly

Before removing the valve, make sure that the plant on which it is mounted is not under pressure and that there is no pressure within the valve.

Ordinary maintenance

Checking the seals of the shutter and the seat on the system at each opening of the valve or every 6 months of operation. Periodic retest

according to the related standards of the country of installation. In Italy, see the Ministerial Decree 329 dd. 12/01/2004: for fluids of the group 1: every 2 years you must carry out a functional test and every 10 years you must check the integrity; for fluids of the group 2, every 3 years, you must check the operation and every 10 years you must check the integrity.

8.1.18 SIZING (Nitrogen flow rate)

In most cases, the flow rate of the valve ensures the fire safety function as the pressure rises gradually with the temperature and therefore the required flow rate will hardly be higher than the minimum value guaranteed by the valve.

For an exact calculation of the maximum guaranteed flow rate, please refer to the UNI EN 4126-1 standard that can be summarized with the formula shown below and applied to calibration pressures greater than 5 bar for which the discharge regime is definitely critical and then you must apply the following formulas

$$\text{Mass flow rate } Q_m = 0,2883 \times C \times A \times K_{dr} \times \sqrt{p_0 \times \rho} \quad (\text{kg/h})$$

$$\text{Volume flow rate } Q_v = 4,806 \times C \times A \times K_{dr} \times \sqrt{p_0 / \rho} \quad (\text{l/m})$$

Where: C = 2,703 is a flow coefficient; A = 50.27 is the minimum area of transition expressed in mm²; K_{dr} = 0.855 is the discharge coefficient of the that is typical of the K_d valve reduced by 10%; p₀ is the discharge pressure in absolute bar; ρ is the density in kg/m³

To give a more precise indication, below please find a table with the values calculated at 150°C.

Po (barg)	10	25	50	100	250	360	400
Qv (l/m)	620	630	630	640	660	685	690
Qm (kg/h)	300	750	1.500	2.900	7.100	9.800	11.000

In summary, with the gas at a temperature of 150°C, and passing by the pressure of 10 bar to that of 400 bar, the volumetric flow rate varies from 620 to 690 l/m; the mass flow instead varies much more because the density of the gas is approximately proportional to the pressure, and then passes from 300 to 11,000 kg/h.

These data already take into account the notional reduction of 10% set by the EN 4126 standard, and then the actual flow rate will always be greater.

Always as indicative data, the flow rate of at least 600 l/m in all conditions implies that the pressure in a hypothetical group of accumulation of 6000 liters will drop of about 10% per minute regardless of the value of the pressure itself. This example involves the extreme rapidity idea of the gas outflow.